

GRIPWASHER BS-Disc



Specifications

- No additional counter-holding measures or second person required for bolted joint assembly
- Immediate, effective locking even at low preload forces
- Ideal for installation in confined spaces
- Tightening and loosening possible with access from only one side
- Friction based positive locking
- Effectively prevents turning on the passive side
- Prevention of accidents at work by eliminating reaction arms
- Protection against self-rotation when combined with the GripWasher NS-Disc

GRIPWASHER BS-Disc

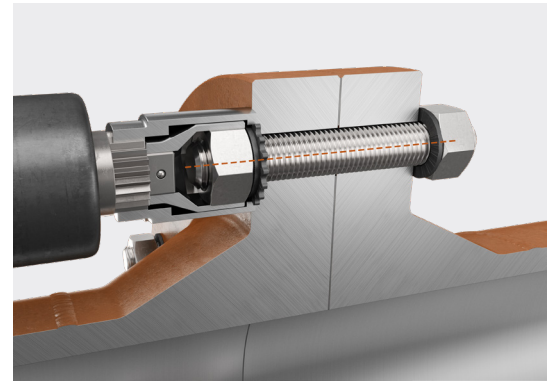

Using a GripWasher NS-Disc and BS-Disc in a through hole

Technical data

- Backup-washer for use with the GripWasher NS-Disc
- Material: 1.1191 (C45E) with black zinc flake coating (flZnnc)
- Hardness: 485±25 HV0,3
- Corrosion resistance: min.1,000 h in NSS-test according to ISO 9227
- Suitable for high-strength bolts and nuts up to strength class 12.9 / 12
- Available dimensions: M16 - M48 ($\frac{5}{8}$ "- 1 3/4")
- Other nominal sizes, materials and coatings available on request

Models

GWBS_16	M16
GWBS_18	M18
GWBS_20	M20
GWBS_22	M22
GWBS_24	M24

GWBS_27	M27
GWBS_30	M30
GWBS_33	M33
GWBS_36	M36
GWBS_39	M39

GWBS_42	M42
GWBS_45	M45
GWBS_48	M48