

## Manual flange spreader „Easy“

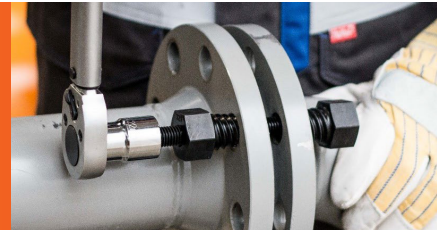

### Specifications

- User-friendly
- Facilitates safe work practices
- To be used in pairs
- A practical and simple alternative to conventional methods
- Affordable and cost-effective
- Compact size and low weight: it will fit in any toolbox
- Will not damage flange and gasket
- For onshore & offshore applications
- Also applicable when there is no gap between the flanges

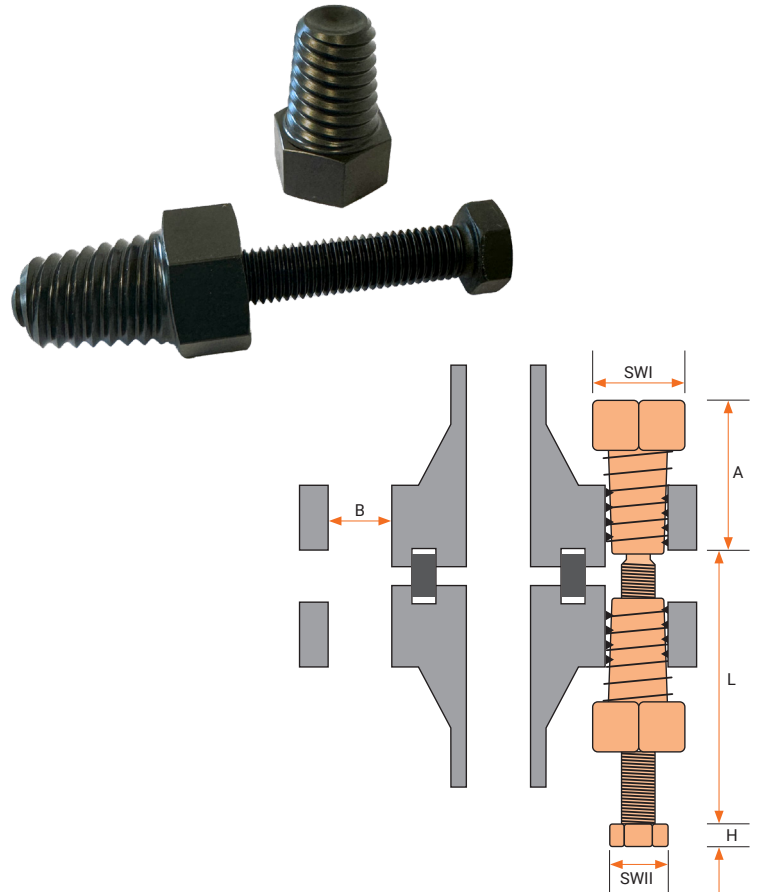

### Models

	Spreading force	SW I	SW II	H	L	A	B	
<b>TNFFS-22</b>	10 t	22 mm	13 mm	5 mm	85 mm	34 mm	14 – 15,9 mm	5/8 "
<b>TNFFS-27</b>	10 t	27 mm	17 mm	7 mm	100 mm	47 mm	18 – 19,1 mm	3/4 "
<b>TNFFS-32</b>	8,5 t	32 mm	22 mm	9 mm	110 mm	50 mm	22,2 – 23 mm	7/8 "
<b>TNFFS-36</b>	7,5 t	36 mm	24 mm	11 mm	130 mm	56 mm	25,4 – 27 mm	1 "
<b>TNFFS-41</b>	7 t	41 mm	27 mm	12 mm	140 mm	64 mm	28,6 – 30 mm	1 1/8 "
<b>TNFFS-46</b>	6 t	46 mm	30 mm	13 mm	200 mm	73 mm	31,8 – 33 mm	1 1/4 "
<b>TNFFS-50</b>	6 t	50 mm	30 mm	13 mm	200 mm	73 mm	34,9 – 36 mm	1 3/8 "
<b>TNFFS-55</b>	5,5 t	55 mm	32 mm	14 mm	225 mm	73 mm	38,1 – 39 mm	1 1/2 "
<b>TNFFS-60</b>	4,5 t	60 mm	32 mm	14 mm	225 mm	77 mm	41,3 – 42 mm	1 5/8 "
<b>TNFFS-65</b>	4 t	65 mm	32 mm	14 mm	225 mm	77 mm	44,5 – 48 mm	1 3/4 – 1 7/8 "

## Technical data

### ● Scope of application ANSI

	1/2"	3/4"	1"	1 1/4"	1 1/2"	2"	2 1/2"	3"	3 1/2"	4"
<b>150#</b>	MMS-22	MMS-22	MMS-22	MMS-22	MMS-22	MMS-27	MMS-27	MMS-27	MMS-27	MMS-27
<b>300#</b>	MMS-22	MMS-27	MMS-27	MMS-27	MMS-32	MMS-27	MMS-32	MMS-32	MMS-32	MMS-32
<b>400#</b>	MMS-22	MMS-27	MMS-27	MMS-27	MMS-32	-	MMS-32	MMS-32	MMS-36	MMS-36
<b>600#</b>	MMS-22	MMS-27	MMS-27	MMS-27	MMS-32	MMS-27	MMS-32	MMS-32	MMS-36	MMS-36
<b>900#</b>	MMS-32	MMS-32	MMS-36	MMS-36	MMS-41	MMS-36	MMS-41	MMS-36	-	MMS-46
<b>1500#</b>	MMS-32	MMS-32	MMS-36	MMS-36	MMS-41	MMS-36	MMS-41	MMS-46	-	MMS-50
<b>2500#</b>	MMS-32	MMS-32	MMS-36	MMS-41	MMS-46	MMS-41	MMS-46	MMS-50	-	MMS-60

	5"	6"	8"	10"	12"	14"	16"	18"	20"	24"
<b>150#</b>	MMS-32	MMS-32	MMS-32	MMS-36	MMS-36	MMS-41	MMS-41	MMS-46	MMS-46	MMS-50
<b>300#</b>	MMS-32	MMS-32	MMS-36	MMS-41	MMS-46	MMS-46	MMS-50	MMS-50	MMS-50	MMS-60
<b>400#</b>	MMS-36	MMS-36	MMS-41	MMS-46	MMS-50	MMS-50	MMS-55	MMS-55	MMS-60	MMS-65
<b>600#</b>	MMS-41	MMS-41	MMS-46	MMS-50	MMS-50	MMS-55	MMS-60	MMS-65	MMS-65	-
<b>900#</b>	MMS-50	MMS-46	MMS-55	MMS-55	MMS-55	MMS-60	MMS-65	-	-	-
<b>1500#</b>	MMS-60	MMS-55	MMS-65	-	-	-	-	-	-	-
<b>2500#</b>	MMS-65	-	-	-	-	-	-	-	-	-

### ● Scope of application DIN

	DIN 10	DIN 15	DIN 25	DIN 32	DIN 40	DIN 50	DIN 65	DIN 80	DIN 100	DIN 125
<b>PN 6</b>	-	-	-	MMS-22	MMS-22	-	MMS-22	MMS-27	MMS-27	MMS-27
<b>PN 10</b>	MMS-22	MMS-22	MMS-22	MMS-27	MMS-27	MMS-22	MMS-27	MMS-27	MMS-27	MMS-27
<b>PN 16</b>	MMS-22	MMS-22	MMS-22	MMS-27	MMS-27	MMS-27	MMS-27	MMS-27	MMS-27	MMS-27
<b>PN 25</b>	MMS-22	MMS-22	MMS-22	MMS-27	MMS-27	MMS-27	MMS-27	MMS-27	MMS-32	MMS-36
<b>PN 40</b>	MMS-22	MMS-22	MMS-22	MMS-27	MMS-27	MMS-27	MMS-27	MMS-27	MMS-32	MMS-36
<b>PN 64</b>	MMS-22	MMS-22	MMS-27	MMS-32	MMS-32	MMS-32	MMS-32	MMS-32	MMS-36	MMS-41
<b>PN 100</b>	MMS-22	MMS-22	MMS-27	MMS-32	MMS-32	MMS-36	MMS-36	MMS-36	MMS-41	MMS-46
<b>PN 160</b>	MMS-22	MMS-22	MMS-27	-	MMS-32	MMS-36	MMS-36	MMS-36	MMS-41	MMS-46

	DIN 150	DIN 175	DIN 200	DIN 250	DIN 300	DIN 350	DIN 400	DIN 500	DIN 600
<b>PN 6</b>	MMS-27	-	MMS-27	MMS-27	MMS-32	MMS-32	-	MMS-32	MMS-32
<b>PN 10</b>	MMS-32	MMS-32	MMS-32	MMS-32	MMS-32	MMS-32	MMS-32	MMS-36	MMS-41
<b>PN 16</b>	MMS-32	MMS-32	MMS-32	MMS-27	MMS-36	MMS-36	MMS-41	MMS-46	MMS-50
<b>PN 25</b>	MMS-36	MMS-36	MMS-36	MMS-41	MMS-41	MMS-46	MMS-50	MMS-50	MMS-55
<b>PN 40</b>	MMS-36	MMS-41	MMS-41	MMS-46	MMS-46	MMS-50	MMS-55	MMS-60	MMS-65
<b>PN 64</b>	MMS-46	MMS-46	MMS-50	MMS-50	MMS-50	MMS-55	MMS-60	MMS-65	-
<b>PN 100</b>	MMS-46	MMS-46	MMS-50	MMS-55	MMS-60	MMS-60	-	-	-
<b>PN 160</b>	MMS-46	MMS-50	MMS-50	MMS-60	MMS-60	-	-	-	-